

# Electronic manipulation of DNA and proteins for potential nano-bio circuit assembly

Lifeng Zheng<sup>a</sup>, Peter J. Burke<sup>\*a,b</sup>, James P. Brody<sup>b</sup>

<sup>a</sup>Department of Electrical Engineering and Computer Science, and

<sup>b</sup>Department of Biomedical Engineering  
Integrated Nanosystems Research Facility

University of California, Irvine

Irvine, CA 92697

## ABSTRACT

Using gold electrodes lithographically fabricated onto microscope cover slips, DNA and proteins are interrogated both optically (through fluorescence) and electronically (through conductance measurements). Dielectrophoresis is used to position DNA and proteins at well-defined positions on a chip. For the electronic manipulations, quadrupole electrode geometries are used with gaps ranging from 3 to 100  $\mu\text{m}$ ; AC field strengths are typically  $10^6$  V/m with frequencies between 10 kHz and 30 MHz. Nanoparticles (20 nm latex beads) are also manipulated. A technique of in situ impedance monitoring is tested for the first time to measure the conductance of the electronically manipulated DNA and proteins. The electrical resistance of DNA and proteins is measured to be larger than 40 M $\Omega$  under the experimental conditions used.

**Keywords:** Dielectrophoresis, DNA, Proteins, Nanoparticles

## 1. INTRODUCTION

### 1.1. Motivation

The development of lithographic fabrication techniques has led to astounding advances in integrated circuits, but at the same time the limits of lithography prevent nanometer scale electronic devices from being economically manufactured. This has led to proposals for alternative nano-manufacturing technologies based on "bottom-up" chemical self-assembly techniques.

Two key challenges in the manufacturing of sub-lithographic size electronic devices (i.e., molecular electronics<sup>1</sup>) are 1) Chemical (i.e. bottom-up) control of the electronic properties of the circuit elements, and 2) Electrical connection to the macroscopic world. One approach to the challenge of chemical control is *de-novo* design of unique chemistry for electronics applications<sup>2</sup>. An alternative approach is to build on 4 billion years of evolution and use or mimic existing biochemistry, using DNA as a template for chemically programmed assembly of molecular scale devices. Recently several groups have made important progress in using DNA as a template for the construction of higher order structures<sup>3,4,5,6</sup>. Because of the attractiveness of the second approach we have decided to concentrate on the electronic manipulation and interrogation of DNA and proteins in this work.

The second challenge of making an electrical connection to the macroscopic world to date has mostly been achieved passively. Much work to date on single molecule devices involves passive diffusion of molecules to small, albeit lithographically fabricated electrodes followed by passive covalent bonding to the electrode<sup>7</sup>. It would be a distinct advantage if this assembly process could be actively, electronically controlled.

### 1.2. Dielectrophoresis

Dielectrophoresis (hereafter DEP) is an electronic analog of optical tweezers using audio frequency, RF, and microwave electric fields generated from microfabricated electrodes on a chip. An AC electric field induces a dipole moment which, in the presence of a field gradient, experiences a force towards either the high-field intensity region (positive

---

\* Email: [pjburke@uci.edu](mailto:pjburke@uci.edu); phone 1 949 824 9326; website <http://nano.ece.uci.edu>

DEP) or the low-field intensity region (negative DEP). Several recent reviews<sup>8,9,10,11,12,13,14</sup> more thoroughly describe the many applications of DEP at the micron, sub-micron, and nanometer scale. As with optical tweezers, for DEP to be of use it must dominate the thermal Brownian motion.

It can be shown that the force acting on a spherical particle (the DEP force) is given by<sup>15,16</sup>

$$\vec{F}_{DEP} = 2\pi v \epsilon_m \alpha_r \vec{\nabla} (\vec{E}_{RMS}^2), \quad (1)$$

where  $v$  is the volume of the particle,  $E_{RMS}$  the RMS value of the electric field (assuming a sinusoidal time dependence), and  $\alpha_r$  is a factor which varies between -0.5 and +1.0, depending on the difference between the medium and particle dielectric constant. If  $\alpha_r$  is positive, then the particle is attracted to regions of high electric field intensity. (This is called positive DEP.) If  $\alpha_r$  is negative, then the particle is repelled from regions of high electric field intensity. (This is called negative DEP.) Since the dielectric properties of both the particle and medium are frequency dependent, both positive and negative DEP can be observed in the same system by varying the frequency.

For this force to be effective it must overcome the Brownian motion, which can be treated as a random force whose maximum value is given roughly by<sup>15,16</sup>

$$F_{thermal} = k_B T / \sqrt[3]{v}, \quad (2)$$

where  $k_B$  is the Boltzmann constant,  $T$  the temperature, and  $v$  the particle volume. This sets a rather strict requirement on the minimum particle size that can be manipulated, and very large electric field gradients are needed to manipulate nano-sized particles. Microfabricated electrodes can be used to generate the required field gradients, although the lower limit on the particle size that can be manipulated is still under experimental investigation<sup>17</sup>.

### 1.3. DNA manipulation

Starting in 1990, Washizu and Kurosawa began studies on manipulating and stretching DNA in high intensity AC electric fields generated by microfabricated electrodes<sup>18</sup>. They found that a high-frequency electric field would stretch DNA into a line, whereas its natural configuration is coiled. In 1995, Washizu and co-workers described several possible applications of this technology<sup>19</sup>, such as size-sorting long DNA which is difficult for conventional gel electrophoresis. Before 1998, all published work on manipulating DNA with this technique had been performed by or in collaboration with Washizu<sup>18,19,20,21,22,23,24</sup>. Later on, Asbury and co-workers trapped DNA with a floating electrode geometry<sup>25</sup>. They found that DNA did not attach to gold electrodes in contrast to Washizu's experiments where DNA did attach to aluminum electrodes. In another work with floating electrodes, Chou and co-workers used insulating posts fabricated with micromachining techniques, and electrodes external to the device<sup>26</sup>. They found the trapping force increases with frequency. Tsukahara and co-workers used quadrupole electrodes and found DNA was pushed away from electrodes between 500 kHz and 1 MHz<sup>27</sup>. Recently, Dewarrat and coworkers optimized the geometry of the lithographic structures to favor a precise positioning of DNA<sup>28</sup>. Namasiwayam and co-workers trapped single DNA molecules and found that  $\lambda$ -DNA were fully stretched at 1 MHz and partially stretched at 1kHz<sup>29</sup>. Holzel and co-workers also recently used DEP to concentrate and align DNA molecules<sup>30</sup>. Germushuizen and co-workers also recently manipulated DNA with DEP<sup>31</sup>. None of these authors have measured the electrical properties of the DNA after manipulation.

Thus, while most of this research work focused on manipulating DNA and proteins, investigation of their electrical properties is still in its infancy. Since it was suggested that DNA can transport electrons from site to site by Barton's group<sup>32</sup>, experiments performed by different research groups have indicated that DNA has insulating, semiconducting, metallic and even superconducting properties<sup>33,34,35,36,37,38,39</sup>. These differing results of the electrical properties of DNA indicate that effective methods should be set up for the measurements. As for the electrical properties of proteins, these biological nanostructures have yet (until now) to be interrogated electrically. Our work in this paper represents the first step in this direction. Since various proteins have many differing chemical and mechanical properties, it can be argued that their electrical properties will be even more diverse (and hence interesting) than that of DNA.

#### 1.4. This research work

In this work, a technique is presented that may be useful for the electronic control of manufacturing devices at the molecular scale by controlling the position of DNA and proteins on a chip to fabricate simple electrical circuits (a conductor bridging a gap). We apply our technique to DNA and proteins to measure, for the first time, the conductance of DNA and proteins trapped between two electrodes using dielectrophoresis by *in situ* monitoring the impedance change of the DNA and protein solutions. This technique contains the rudimentaries of single molecule transistor fabrication with an essentially nano-electrochemistry approach<sup>40</sup>. What is new about this approach is 1) It is the first measurement of the conductivity of DNA after DEP manipulation, 2) It is the first ever measurement of the electrical properties of any protein, 3) It is a new technique to fabricate nano-circuits using AC voltages.

## 2. MATERIALS AND METHODS

### 2.1. Electrode design and fabrication

For our experiments, electrodes were fabricated using photolithography onto microscope cover slides. Ti (10 nm)/Au(100 nm) bilayers were deposited with electron-beam evaporation and lifted off in acetone. The geometry of the electrodes was designed for both positive and negative DEP experiments. For negative DEP, Huang and Pethig<sup>41</sup> have shown that a planar, "quadrupole" electrode geometry allows the trapping of particles under the influence of negative DEP in the center of the electrodes, called the "trap." This is because there is an electric field gradient minimum in region of the center of the electrodes, and particles undergoing negative DEP are repelled from the higher field regions. We have also performed numerical simulations for our electrode geometry, which is slightly different from the geometry considered by Huang<sup>41</sup>. We find that the electric field gradient is maximum in the region closest to the electrode edges. Thus, for particles which undergo positive DEP, they should be attracted to those regions.

### 2.2. Sample preparation

Solutions containing either fluorescently labeled  $\lambda$ -phage DNA, BSA protein, or 20 nm latex beads were prepared as described below. A drop was placed on the cover slip with electrodes, which is then covered by a second slip. This configuration was necessary for the inverted microscope configuration used. An RF function generator was used to apply electric fields in the frequency range of 10 kHz to 30 MHz, and applied voltages of up to 10 V<sub>pp</sub>.

### 2.3. Optical interrogation

The solution was imaged through an inverted Nikon TE200 microscope, equipped with a 40x/1.3NA objective. Fluorescent images used epi-illumination with a mercury arc lamp providing the excitation. A back-illuminated, slow-scan, cooled CCD camera (AP7P, from Apogee Instruments) captured the images.

### 2.4. Electronic interrogation

After trapping, the low frequency (13 Hz) conductance between two electrodes was measured simultaneously while applying the AC electric field. The circuit used for the measurement is shown in Fig. 1 below. The high frequency electric field was used to trap the DNA or protein between the electrode gaps. A small amplitude, AC voltage was simultaneously applied and a lock-in-analyzer simultaneously measured the 13 Hz AC current. The 13 Hz current was monitored continuously as the solution dried in order to measure the conductance in both the wet and dry state.

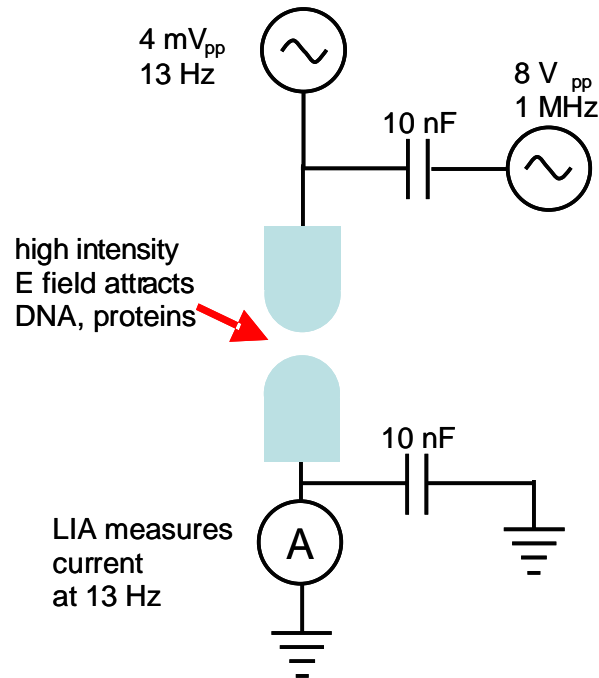

Fig. 1. Circuit for conductance measurements.

It is important to note that, in the experiments described in this paper, the measured conductance corresponds to a large number of molecules trapped electronically between the electrode gaps. While the fluorescence imaging experiments clearly and unambiguously demonstrate the presence of a large number of molecules of either DNA or proteins present in the gap between the electrodes, it remains for future work to provide more quantitative estimates for the number of molecules trapped and to push to the single molecule limit<sup>17</sup>.

### 3. RESULTS AND DISCUSSION

#### 3.1. DNA: optical measurements

The DNA used in the experiments was  $\lambda$ -phage DNA (48.5 kilo-base pairs). The DNA solution was prepared as follows:  $\lambda$ -phage DNA (Promega Corporation, Madison, WI) was purchased in a buffer solution of 10 mM Tris-HCL, 10 mM NaCl, 1 mM EDTA, at a concentration of 500  $\mu\text{g/ml}$ . The solution was diluted  $5 \times 10^5$  times with D.I. water. SYBR green was then added to the solution for the fluorescence measurements.

We observed that DNA under our experimental conditions undergoes positive DEP (i.e. is attracted to high electric field intensity regions) for a range of frequencies between 500 kHz and 1 MHz. Below 500 kHz, no effect was observed. We did not observe DNA to undergo negative DEP under our experimental conditions. We show in Fig. 2 images of successive on/off/on/off conditions of DNA which has been trapped in the high-field region between electrodes with a 10  $\mu\text{m}$  gap. We clearly observe positive DEP (i.e. the DNA is attracted to high electric field intensity regions) over a range of frequencies between 500 kHz and 1 MHz.

We have repeated this experiment dozens of times with electrodes with central gaps of 5  $\mu\text{m}$ , 10  $\mu\text{m}$  and 20  $\mu\text{m}$ . With four electrode geometries with 50  $\mu\text{m}$  gaps, we were unable to see any effect of the electric fields on the DNA for applied voltages of up to 8  $V_{pp}$ . This is consistent with the scaling arguments presented above: large electrodes are less effective in trapping nano-sized objects than smaller electrodes. We have also been able to trap DNA using interdigitated, castellated electrodes with 10  $\mu\text{m}$  gaps. DNA was only observed to undergo positive DEP with those electrodes, as well.

Previous work by Washizu<sup>18,20,21</sup> clearly demonstrated that DNA is stretched and undergoes positive DEP under high intensity electric fields as the ones used in our experiments. Our work is consistent with the work of Washizu but inconsistent with that of other published work on the DEP manipulation of DNA, where both positive and negative DEP was observed by Tsukahara<sup>27</sup>. We speculate that this discrepancy may be related to the different solvents used. Tsukahara used a buffer solution with conductivity of  $4 \times 10^{-3}$  S/m, while our work and that of Washizu<sup>18,20,21</sup> were done with D.I. water as the solvent.

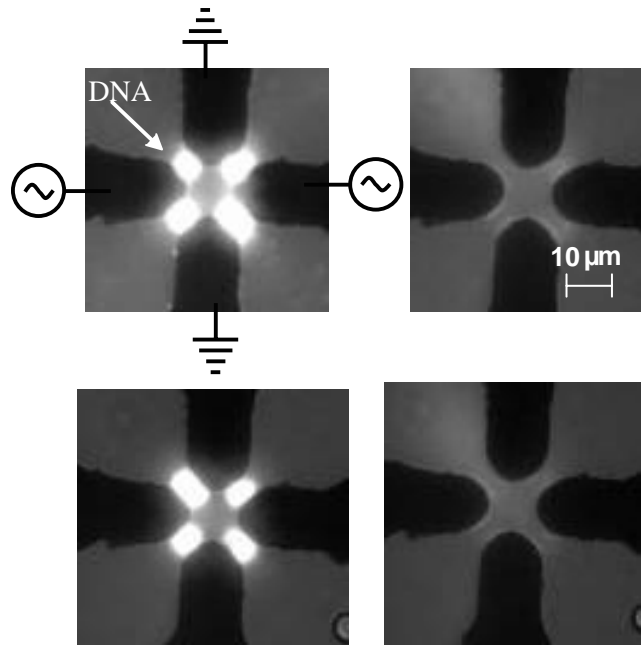

Fig. 2. Images of fluorescently labeled DNA. The four images were taken in on/off/on/off sequence in a time span of about 30 seconds. The applied voltage was 1 MHz, 8 V<sub>pp</sub>.

### 3.2. DNA: electronic measurements

$\lambda$ -phage DNA stretched is 17  $\mu\text{m}$  long, but in its native state it is a randomly coiled ball about 2-4  $\mu\text{m}$  in diameter. In our experiments the gap between the electrodes was less than 5  $\mu\text{m}$  at the nearest point. Although we do not resolve the location of individual DNA molecules in our experiment, based on the findings of Washizu, we expect that the DNA is stretched out and possibly even connects to both electrodes.

In a separate experiment, we applied a drop of solution to the electrodes and monitored the 13 Hz current in response to a small applied AC voltage. A current of 227 nA was measured in the absence of the high frequency signal, due to the background conductivity of ions in the solution. After the 1 MHz AC electric field was applied, no change in the 13 Hz current was measured within a resolution of 0.1 nA. Since we know that DNA can be trapped between electrodes with 1 MHz frequency, no change in the 13 Hz current indicates that DNA has a much lower conductivity than the solution. We then monitored the current change as the solution dried over a period of 72 hours. After the solution dried the measured current was below the noise level of the measurement (0.1 nA).

From the previous experiments, we know that the DNA is attracted to the high electric field regions. From our conductance experiments we conclude that, although the DNA is present, the conductance of the DNA molecules is less than 25 nS, both in the wet state under our solvent conditions as well as in the dry state.

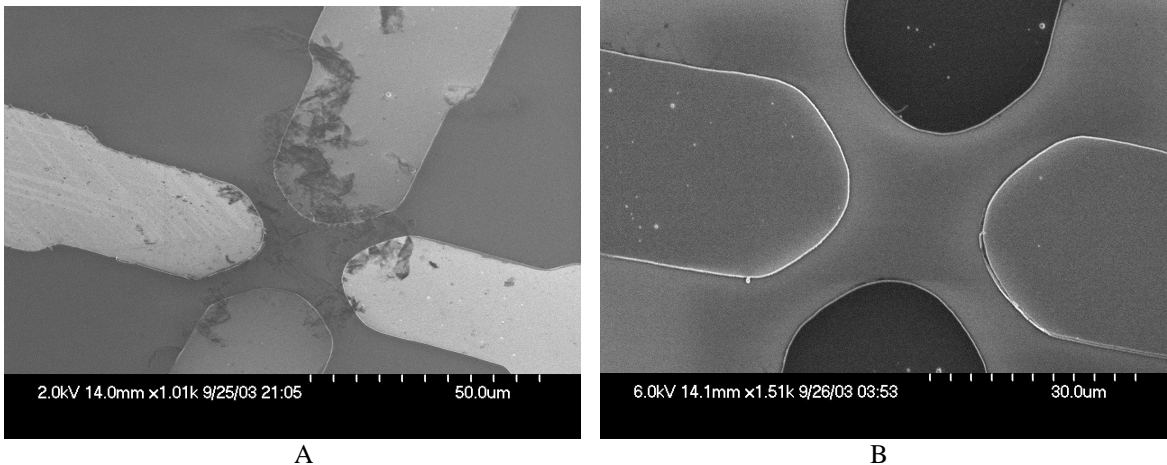

Fig. 3. A. Sample SEM image after drying when DNA solution was used. B. Sample SEM image after drying when only D.I. water was used.

In order to verify that the DNA is indeed trapped electronically, we have conducted a set of control experiments. DNA solution with a concentration of  $10^{-6}$   $\mu\text{g/ml}$  was dropped onto one sample with quadrupole electrodes. For a control sample, D.I. water was dropped onto a similar set of electrodes. An AC bias of  $8 V_{pp}$  at 1 MHz was applied to both samples. Both the DNA solution and D.I. water were dried in air while the voltage was still being applied. The samples were then imaged in an SEM; the SEM pictures are shown in Fig. 3. The dark material between the electrodes shown in Fig. 3A is not seen in the control electrodes shown in Fig. 3B. Since the DNA solution is composed of only  $\lambda$ -phage DNA and D.I. water, we believe that the dark material is DNA itself.

Thus, while we find DNA is not conducting, we have clearly and unambiguously demonstrated that our technique is capable of manipulating DNA to bridge the gap between two electrodes, and that the DNA remains in place even after the solvent dries.

### 3.3. Proteins: optical measurements

For the protein experiments, the sample was prepared as follows: Bovine serum albumin (BSA, molecular weight 68kD) labeled with tetramethylrhodamine (Molecular Probes, Eugene, OR) was dissolved in D.I. water at a concentration of 1 mg/ml and centrifuged. The supernatants were diluted to 1  $\mu\text{g/ml}$  with D.I. water.

We observed that BSA underwent positive DEP for frequencies between 100 kHz - 1 MHz. Negative DEP was not observed at lower frequencies under our experimental conditions. The frequency range of 200-300 kHz was observed to be most effective at attracting the BSA to the high-electric field regions. We show in Fig. 4 images of successive on/off/on/off conditions of BSA which has been trapped in the high-field region between electrodes with a 10  $\mu\text{m}$  gap. We clearly observe positive DEP (i.e. the BSA is attracted to high electric field intensity regions) over a range of frequencies between 100 kHz and 1 MHz. We have repeated this experiment dozens of times with electrodes with central gaps of 5  $\mu\text{m}$ , 10  $\mu\text{m}$  and 20  $\mu\text{m}$ . With four electrode geometries with 50  $\mu\text{m}$  gaps, we were unable to see any effect of the electric fields on the BSA for applied voltages of up to  $8 V_{pp}$ .

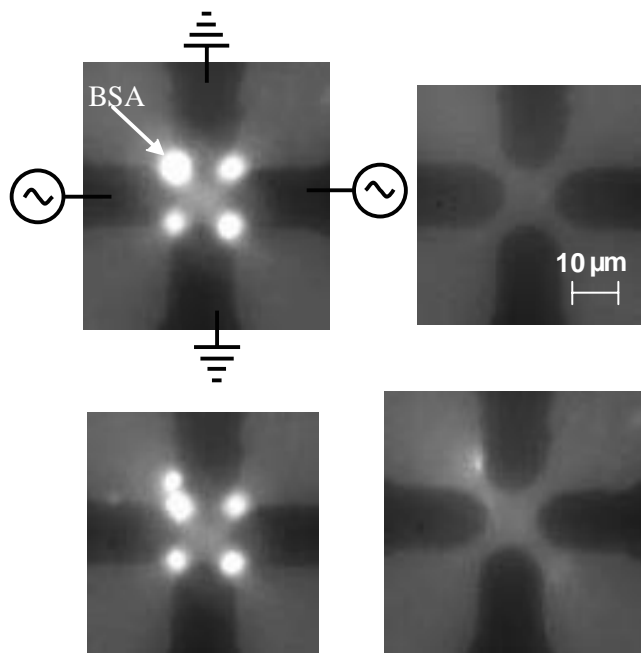

Fig. 4. Images of BSA protein in a span of about 30 seconds.  $f=200$  kHz, amplitude =  $8 V_{pp}$ .

### 3.4. Proteins: electronic measurements

In its folded state BSA should be roughly spherical in geometry with diameter of order 10 nm. Previous work of Washizu has shown that high intensity electric fields can change the conformational state of certain proteins<sup>42</sup>, however the effect of the high-intensity electric field on BSA is unknown. While we were unable to image single BSA molecules under our current experimental setup, it is clear that a large number of BSA molecules were attracted to the gap between the electrodes. With this in mind we measured the conductance at 13 Hz to electrically interrogate the BSA.

In a separate experiment, we applied a drop of solution to the electrodes and monitored the 13 Hz current in response to a small applied AC voltage. A current of 2.5 nA was measured in the absence of the high frequency signal, due to the background conductivity of ions in the solution. (The magnitude of the current was lower than in the DNA experiments because a much smaller amount of solution was placed on the chip in the BSA experiments.) After the 1 MHz AC electric field was applied, as similar to DNA, no change in the 13 Hz current was measured within a resolution of 1 pA, which indicates the conductance of BSA is much less than the conductivity of solution. In another experiment, we monitored the current as the solution dried over a period of 24 hours. After the solution dried the measured current was below the noise level of the measurement (0.1 nA in that measurement).

From the previous experiments, we know that the BSA is attracted to the high electric field regions. From our conductance experiments we conclude that, although the BSA is present, the conductance of the BSA molecules is less than 25 nS, both in the wet state under our solvent conditions as well as in the dry state. Using the technique of dielectrophoresis to manipulate proteins, these measurements represent the first measurements of the electronic properties of proteins. Our measurements indicate that the protein BSA is insulating. This technique could be applied to other proteins as well.

### 3.5. Nanoparticles

In a final set of experiments we were able to use DEP to manipulate fluorescently labeled latex beads of diameter 20 nm (Molecular Probes, Eugene, OR) suspended in D.I. water. Latex beads have served as an ideal test-bed for the use of DEP at the micron and submicron scale<sup>43,44,45</sup> and serve as convincing evidence that under our experimental conditions it is indeed possible to manipulate submicron objects.

For the 20 nm beads, we found that the beads undergo positive DEP for frequencies between 500 kHz and 22 MHz, while above 22 MHz the beads undergo negative DEP. We show in Fig. 5 an image of beads undergoing negative DEP, with an applied frequency of 22 MHz. The beads are seen to be trapped in the center of the electrodes (the fluorescent signals around the edges of electrodes are due to some of beads sticking to electrodes). In Fig. 6, we show an image of beads under the influence of positive DEP, where they are clearly seen attracted to the region of high electric field intensity between the electrodes.

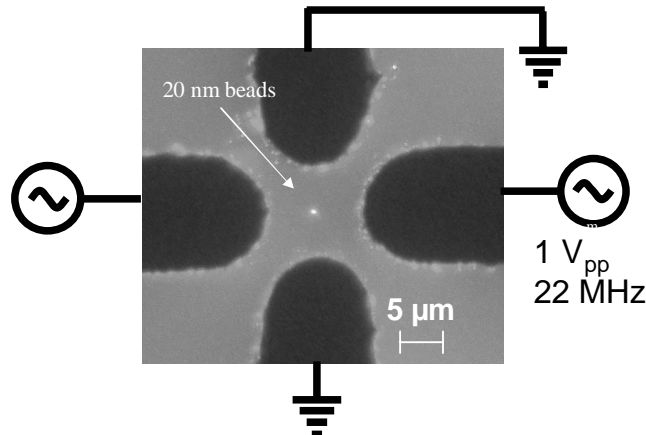

Fig. 5. 20 nm latex beads shown trapped in the center of the electrodes due to negative DEP.

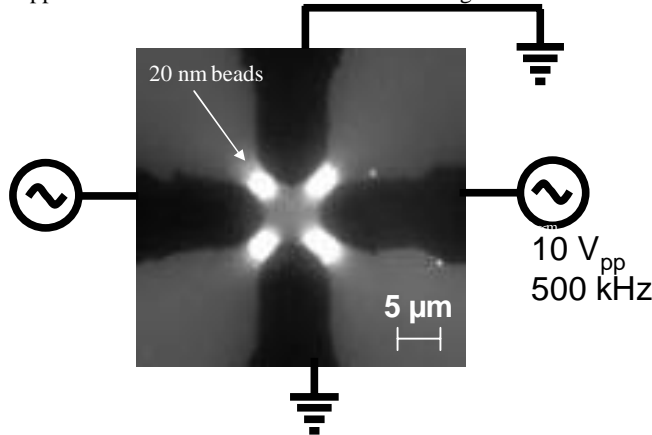

Fig. 6. 20 nm latex beads shown attracted to high electric field regions between the electrodes.

#### 4. CONCLUSIONS

In conclusion, we have shown that DNA, BSA, and 20 nm beads can be manipulated with positive DEP in an aqueous solution. We have measured the conductance of the DNA and BSA and found it to be less than 25 nS. These are the first measurements of DNA conductivity after DEP manipulation, the first ever measurement of the electrical properties of any protein, and represent a new technique to fabricate nano-circuits using AC voltages. While the measured conductance is low (less than our measurement limits in this experiment), our technique for electronically controlled circuit assembly presented herein may be useful for shorter DNA strands or other molecular scale devices, especially when integrated with nanowire and nanotube electrodes<sup>17</sup>.

#### ACKNOWLEDGEMENTS

This work was supported by the U.S. National Science Foundation (ECS-0300557). We thank Alan Lee for assistance with the experiments.



## REFERENCES

1. J. Heath, M. Ratner, "Molecular Electronics", *Physics Today*, **56**, pp. 43-49, 2003.
2. J. M. Tour, "Molecular Wires for Electronic Applications. A Review", *Polymer News*, **25**, pp. 329-336, 2000.
3. E. Braun, Y. Eichen, U. Sivan, G. Ben-Yoseph, "DNA-Templated Assembly and Electrode Attachment of a Conducting Silver Wire", *Nature*, **391**, pp. 775-778, 1998.
4. E. Winfree, F. Liu, L. Wenzler, N. Seeman, "Design and Self-assembly of Two-dimensional DNA Crystals", *Nature*, **394**, pp. 539-544, 1998.
5. C. Mirkin, R. Letsinger, R. Mucic, J. Storhoff, "A DNA-based Method for Rationally Assembling Nanoparticles into Macroscopic Materials", *Nature*, **382**, pp. 607-609, 1996.
6. A. Alivisatos, K. Johnsson, X. Peng, T. Wilson, C. Loweth, M. Bruchez, P. Schultz, "Organization of 'Nanocrystal Molecules' using DNA", *Nature*, **382**, pp. 609-611, 1996.
7. J. Chen, M. A. Reed, "Electronic Transport of Molecular Systems", *Chemical Physics*, **281**, pp. 127-145, 2002.
8. R. Pethig, "Dielectrophoresis: Using Inhomogeneous AC Electrical Fields to Separate and Manipulate Cells", *Critical Reviews in Biotechnology*, **16**, pp. 331-348, 1996.
9. R. Pethig, G. Markx, "Applications of Dielectrophoresis in Biotechnology", *Trends in Biotechnology*, **15**, pp. 426-432, 1997.
10. U. Zimmermann, G. Neil, *Electromanipulation of Cells*, CRC Press, Boca Raton, Florida, 1996.
11. A. Ramos, H. Morgan, N. Green, A. Castellanos, "AC Electrokinetics: A Review of Forces in Microelectrode Structures", *Journal of Physics D: Applied Physics*, **31**, pp. 3338-3353, 1998.
12. N. Green, A. Ramos, H. Morgan, "AC Electrokinetics: A Survey of Sub-micrometre Particle Dynamics", *Journal of Physics D: Applied Physics*, **33**, 632-641, 2000.
13. M. Hughes, "AC Electrokinetics: Applications for Nanotechnology", *Nanotechnology*, **11**, pp. 124-132, 2000.
14. Burke, P.J., "Nano-dielectrophoresis: Electronic Nano-tweezers", *Encyclopedia of Nanoscience and Nanotechnology*, ed. Nalwa, American Scientific Publishers, Stevenson Ranch, CA, 2004 (in press).
15. Pohl, *Dielectrophoresis*, Cambridge University Press, Cambridge, UK, 1978.
16. B. Jones, *Electromechanics of Particles*, Cambridge University Press, Cambridge, UK, 1995.
17. L. Zheng, S. Li, P. Burke, J. Brody, "Towards Single Molecule Manipulation with Dielectrophoresis using Nano-electrodes", *Proceedings of the 3rd IEEE Conference on Nanotechnology*, **1**, pp. 437-440, 2003.
18. M. Washizu, O. Kurosawa, "Electrostatic Manipulation of DNA in Microfabricated Structures", *IEEE Transactions on Industry Applications*, **26**, pp. 1165-1172, 1990.
19. M. Washizu, O. Kurosawa, I. Arai, S. Suzuki, and N. Shimamoto, "Applications of Electrostatic Stretch-and-positioning of DNA", *IEEE Transactions on Industry Applications*, **31**, pp. 447-456, 1995.
20. H. Kabata, O. Kurosawa, I. Arai, M. Washizu, S. Margaron, R. Glass, N. Shimamoto, "Visualization of Single Molecules of RNA Polymerase Sliding along DNA", *Science*, **262**, pp. 1561-1563, 1993.
21. M. Washizu, S. Suzuki, O. Kurosawa, T. Nishizaka, T. Shinohara, "Molecular Dielectrophoresis of Biopolymers", *IEEE Transactions on Industry Applications*, **30**, pp. 835-843, 1994.
22. M. Ueda, H. Iwasaki, O. Kurosawa, and M. Washizu, "Atomic Force Microscopy Observation of Deoxyribonucleic Acid Stretched and Anchored onto Aluminum Electrodes", *Jpn. J. Appl. Phys.*, **38**, pp. 2118-2119, 1999.
23. S. Suzuki, T. Yamannashi, S. Tazawa, O. Kurosawa, and M. Washizu, "Quantitative Analysis of DNA Orientation in Stationary AC Electric Fields using Fluorescence Anisotropy", *IEEE Transactions on Industry Applications*, **34**, pp. 75-83, 1998.
24. T. Yamamoto, O. Kurosawa, H. Kabata, N. Shimamoto, M. Washizu, "Molecular Surgery of DNA Based on Electrostatic Manipulation", *IEEE Transactions on Industry Applications*, **36**, pp. 1010-1017, 2000.
25. C. Asbury, G. van den Engh, "Trapping of DNA in Nonuniform Oscillating Electric Fields", *Biophysical Journal*, **74**, pp. 1024-1030, 1998.
26. C. Chou, J. Tegenfeldt, O. Bakajin, S. Chan, E. Cox, N. Darnton, T. Duke, R. Austin, "Electrodeless Dielectrophoresis of Single- and Double-strand DNA", *Biophysical Journal*, **83**, pp. 2170-2179, 2002.
27. S. Tsukahara, K. Yamanaka, H. Watarai, "Dielectrophoretic Behavior of Single DNA in Planar and Capillary Quadrupole Microelectrodes", *Chemistry Letters*, **3**, pp. 250-251, 2001.
28. F. Dewarret, M. Calame, C. Schonberger, "Orientation and Positioning of DNA Molecules with an Electric Field Technique", *Single Molecules*, **3**, pp. 189-193, 2002.
29. V. Namasivayam, R. Larson, D. Burke, M. Burns, "Electrostretching DNA Molecules using Polymer-enhanced Media within Microfabricated Devices", *Analytical Chemistry*, **74**, pp. 3378-3385, 2002.

30. R. Holzel, N. Gajovic-Eichelmann, F. Bier, "Oriented and Vectorial Immobilization of Linear M13 dsDNA Between Interdigitated Electrodes – Towards Single Molecule DNA Nanostructures", *Biosensors and Bioelectronics*, **18**, pp. 555-564, 2003.
31. W. Germishuizen, C. Walti, R. Wirtz, M. Johnston, M. Pepper, A. Davies, A. Middelberg, "Selective Dielectrophoretic Manipulation of Surface-immobilized DNA Molecules", *Nanotechnology*, **14**, pp. 896-902, 2003.
32. D. Hall, R. Holmlin, J. Barton, "Oxidative DNA Damage through Long-range Electron Transfer", *Nature*, **382**, pp. 731-735, 1996.
33. P. de Pablo, F. Moreno-Herrero, J. Colchero, J. Herrero, P. Herrero, A. Baró, P. Ordejón, J. Soler, E. Artacho, "Absence of dc-Conductivity in  $\lambda$ -DNA", *Physics Review Letter*, **85**, pp. 4992-4995, 2000.
34. A. Strom, J. van Noort, D. de Vries, C. Dekker, "Insulating Behavior for DNA Molecules between Nanoelectrodes at the 100 nm Length Scale", *Applied Physics Letters*, **79**, pp. 3881-3883, 2001.
35. D. Porath, A. Bezryadin, S. de Vries, C. Dekker, "Direct Measurement of Electrical Transport through DNA Molecules", *Nature*, **403**, pp. 635-638, 2000.
36. L. Cai, H. Tabata, T. Kawai, "Self-assembled DNA Networks and Their Electrical Conductivity", *Applied Physics Letters*, **77**, pp. 3105-3106, 2000.
37. Y. Okahata, T. Kobayashi, K. Tanaka, "Anisotropic Electric Conductivity in an Aligned DNA Cast Film", *Journal of the American Chemical Society*, **120**, pp. 6165-6166, 1998.
38. H. Fink, Schonenberger, "Electrical Conduction through DNA Molecules", *Nature*, **398**, pp. 407-410, 1999.
39. A. Kasumov, M. Kociak, S. Gueron, B. Reuket, V. Volkov, D. Klinov, H. Bouchiat, "Proximity-Induced Superconductivity in DNA", *Science*, **291**, pp. 280-282, 2001.
40. F. Fan, A. J. Bard, "Electrochemical Detection of Single Molecules", *Science*, **267**, pp. 8971-8974, 1995.
41. Y. Huang, R. Pethig, "Electrode Design for Negative Dielectrophoresis", *Measurement Science and Technology*, **2**, pp. 1142-1146, 1991.
42. M. Washizu, M. Shikida, S. Aizawa, H. Hotani, "Orientation and Transformation of Flagella in Electrostatic Field", *IEEE Transactions on Industry Applications*, **28**, pp. 1194-1202, 1992.
43. T. Muller, A. Gerardino, T. Schnelle, S. Shirley, F. Bordoni, G. De Gasperis, R. Leoni, G. Fuhr, G., "Trapping of Micrometre and Sub-micrometre Particles by High-frequency Electric Fields and Hydrodynamics Forces", *Journal of Physics D: Applied Physics*, **29**, pp. 340-349, 1996.
44. N. Green, H. Morgan, "Dielectrophoretic Separation of Nanoparticles", *Journal of Physics D: Applied Physics*, **30**, pp. L41-L48, 1997.
45. N. Green, H. Morgan, "Dielectrophoresis of Submicrometer Latex Spheres. 1. Experimental Results", *Journal of Physical Chemistry B*, **103**, pp. 41-50, 1999.